

# Series GT200

Aerospace Pressure Transducers



## Description

The Series GT200 pressure transducer is a reliable and rugged mV/V pressure sensor. The major design feature is a fully cleanable pressure cavity. These pressure transducers are used for applications involving dynamic and static pressure measurements requiring high frequency response and are industry standards for rocket engine testing and jet engine testing. The Series GT200 is designed with a unique sensing element which is isolated from the diaphragm thus providing improved thermal stability during the initial phases of testing. The removable pressure caps incorporate metal-to-metal seals eliminating the use of O-rings. Other design features include long term stability, low sensitivity to both mechanical shock and vibration and thermal shock, excellent response to transient pressures, infinite resolution and built in over pressure protection. Each GT200 pressure transducer is shipped with a 19 point calibration record traceable to NIST as standard.

## Standard Features

- Fully Cleanable Pressure Cavity
- Thermal Stability
- High Frequency Response
- 316 SS Wetted Material Thru 2000 psi
- Built In Over Pressure Protection
- Removable Pressure Caps with Metal-To-Metal Seals
- 3 mV/V Output
- Low Sensitivity to Shock and Vibration
- Pressure Ranges to 20,000 PSIA and PSIG (sealed)
- All Stainless Steel Construction
- 19 Point Calibration Record Traceable to NIST

## Optional Features

- Improved Thermal Coefficients
- Customer Specified Pressure Ports
- Customer Specified Electrical Connections
- Extended Temperature Compensation Ranges
- Alternate Materials for Media Compatibility
- Special Calibrations

**GT200**

# Series GT200 Specifications

Baseline Configuration Specs Represented.  
Modifications Encouraged - See Below  
Custom Designs Available

## Performance

### Static Accuracy

Linearity:  $\pm 0.25\%$  FSO.  
Hysteresis:  $\pm 0.25\%$  FSO.  
Repeatability:  $\pm 0.10\%$  FSO.

### Resolution

Infinite

### Thermal Zero Shift

$< \pm 0.010\%$  FSO/ $^{\circ}$ F.  
( $< \pm 0.005\%$  optional)

### Therm. Sens. Shift

$< \pm 0.005\%$  FSO/ $^{\circ}$ F.

### Input / Output Resistance

$350 \pm 3.5$  ohms at  $70^{\circ}$ F.

### Insulation Resistance

$> 10K$  megohms at 50 Vdc at  $70^{\circ}$ F.

### Zero Balance

$\pm 1\%$  FSO at  $70^{\circ}$ F.

### Full Scale Output

$3.0 \pm 0.015$  mV/V FSO at  $70^{\circ}$ F.

### Natural Frequency

0 kHz at 2 PSI to 150 kHz at  
20,000 PSI.

### Acceleration Response

Less than  $\pm 0.10\%$  FSO/G at 15 PSI to  
 $\pm 0.0015\%$  FSO/G at 20K PSI.

## Mechanical Characteristics

### Standard Ranges

0 - 2, 3, 5, 10, 15, 20, 25 PSIA  
30, 50, 75, 100, 150, 200, 300, 500, 750,  
1000, 1500, 2000, 3000, 3500, 4000,  
5000, 7500, 10000, 15000, 20000  
PSIA or PSIG sealed.

### Proof Pressure

2 - 100 PSI ranges: 500 PSI.  
150 - 2K PSI ranges: 2.5 X range.  
3.0K PSI range and up: 1.5 X range.

### Operating Media

Fluids and gases compatible with 316  
stainless steel for ranges thru 2000 PSI  
and 17-4 PH stainless steel for ranges  
3000 PSI thru 20000 PSI.

## Mechanical Characteristics

### Pressure Fitting

(For ranges up to & including 10,000 psi)  
7/16"-20 per AS5202E4 / MS33649-4  
(Female).

(For ranges 15K psi and 20K psi)  
AE F250-C, 9/16"-18 UNF (Female).  
Note: Pressure cap is removable.

### Enclosure

Body and pressure cavity of  
stainless steel, environmentally sealed.

### Weight

55 oz. maximum.

## Electrical Characteristics

### Excitation

10 Vdc recommended, 15 Vdc max.

### Electrical Termination

MS3102-14S-2P stainless steel connector  
or equivalent.  
Optional electrical terminations available.

### Wiring

PIN A (+) Excitation.  
PIN B (+) Signal.  
PIN C (-) Signal.  
PIN D (-) Excitation.  
Standard configuration shown.  
Options available.

## Environmental Characteristics

### Compensated Temperature Range

$-30^{\circ}$ F to  $+170^{\circ}$ F.  
( $-65^{\circ}$ F to  $+250^{\circ}$ F optional)

### Operating Temperature Range

$-100^{\circ}$ F to  $+300^{\circ}$ F.

## Dimensions (inches)

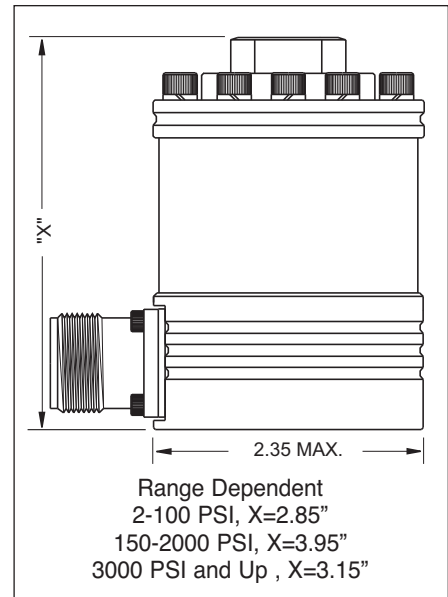

## Modifications and Warranty

MODIFICATIONS: We realize transducer applications vary greatly and as such our designs are flexible. Choice of pressure port, electrical termination, material compatibility and performance characteristics are a few of the many options available. Specifications on this datasheet represent the standard configuration only. Product and company names listed are trademarks of their respective companies. Specifications subject to change without notice.

WARRANTY: Stellar Technology warrants that its product shall be free from defective workmanship and/or material for a twelve month period from the date of shipment, provided that Stellar Technology's obligation hereunder shall be limited to correcting any defective material FOB our factory. No allowance will be made for any expenses incurred for correcting any defective workmanship and/or material without written consent by Stellar Technology. This warranty is in lieu of all other warranties expressed or implied.

**LORD** ISO 9001/AS9100  
**SENSING**  
Stellar Technology

Copyright © 2015 LORD Corporation • All Rights Reserved  
Datasheet P/N: 227276E DCN 9338

Due to the nature of technology, changes are inevitable. For latest technical specifications, see our website.

237 Commerce Drive • Amherst, NY 14228 • USA  
Tel: 716.250.1900 • Fax: 716.250.1909  
Web: stellartech.com • Email: info@stellartech.com

