



Series RDE915

Rod-End Tension and Compression Load Cell



Description

The Series RDE915 load cells are rod-end configurations for both in-line tension or in-line compression force applications. Constructed of high strength tool steel, these bonded foil strain gaged force sensors are compact in size and provide reliable performance for demanding application conditions. The RDE915 features low deflection along with shock and vibration protection. In addition, these load cells are environmentally sealed. RDE915 load cells are used in many in-line tension applications such as actuator testing, aircraft and automotive component testing, and materials testing. Each unit is shipped with a 5 point calibration record traceable to NIST as standard.

Standard Features

- 0.25% Accuracy
- Ranges from 5,000 lbf to 25,000 lbf
- Low Deflection
- In-Line Tension or In-Line Compression
- High Strength Tool Steel
- -65°F to 250°F Standard Operating Temperature
- Environmentally Sealed
- Shock and Vibration Resistant
- 5 Point Tension Calibration Record Traceable to NIST

Optional Features

- Metric Versions
- Special Full Scale Ranges
- Special Calibrations
- Dual or Triple Bridges
- -40°F to +400°F Operating Temperature

Performance

Standard Ranges

5K, 10K, 15K, 20K, 25K lbs.

Output

2mV/V nominal.

Linearity

0.25% FSO.

Hysteresis

0.15% FSO.

Repeatability

0.05% FSO..

Temperature Effect on Zero

0.002% FSO/°F.

Temperature Effect on Span

0.002% Reading/°F.

Zero Balance

1% FSO.

Environmental Characteristics

Operating Temperature Range

-40°F to 250°F.

(-40°F to 400°F optional.)

Compensated Temperature Range

70°F to 170°F.

(-40°F to 400°F optional.)

Series RDE915

Specifications

Baseline Configuration Specs Represented.
Modifications Encouraged - See Below
Custom Designs Available

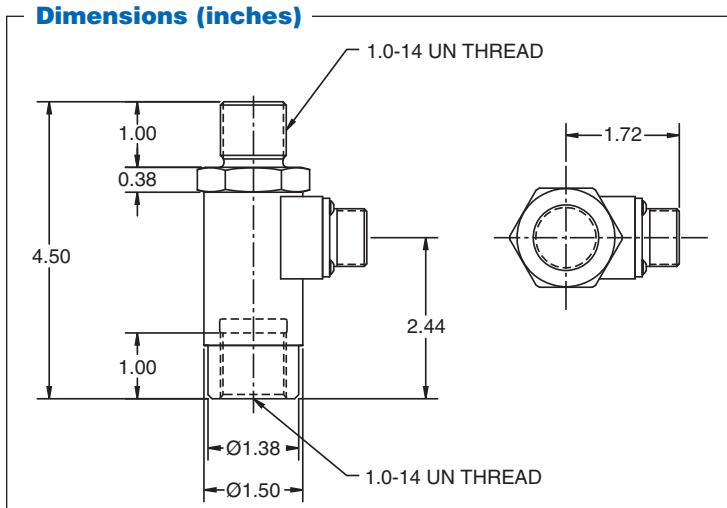

Mechanical Characteristics

Static Overload Without Damage

150% FSO.

Standard Calibration

Tension only:

5 points (0, 50%, 100%, 50%, 0 of FSO).

Optional Calibrations

• Compression only:

5 points (No charge option)

• Tension and Compression:

5 points in each direction

• Special multipoint calibration

(customer specified):

in tension or compression or both tension and compression.

Material

High strength steel,
environmentally sealed.

Electrical Characteristics

Bridge Resistance

350 Ohms nominal.

Excitation

20 Vdc or Vac.

Insulation Resistance

Greater than 5000 megaohms
at 50 Vdc.

Electrical Termination

MS3102E-14S-5P.

Electrical Characteristics

Connector Pins (Standard)

A	+EXE	B	+SIG
C	- SIG	D	- EXE
E	NC		

Customer specified wiring codes
are available.



Modifications and Warranty

MODIFICATIONS: We realize transducer applications vary greatly and as such our designs are flexible. Choice of pressure port, electrical termination, material compatibility and performance characteristics are a few of the many options available. Specifications on this datasheet represent the standard configuration only. Product and company names listed are trademarks of their respective companies. Specifications subject to change without notice.

WARRANTY: Stellar Technology warrants that its product shall be free from defective workmanship and/or material for a twelve month period from the date of shipment, provided that Stellar Technology's obligation hereunder shall be limited to correcting any defective material FOB our factory. No allowance will be made for any expenses incurred for correcting any defective workmanship and/or material without written consent by Stellar Technology. This warranty is in lieu of all other warranties expressed or implied.



ISO 9001/AS9100

Due to the nature of technology, changes are inevitable. For latest technical specifications, see our website.

237 Commerce Drive • Amherst, NY 14228 • USA

Tel: 716.250.1900 • Fax: 716.250.1909

Web: stellartech.com • Email: info@stellartech.com

Copyright © 2015 STI • All Rights Reserved
Datasheet P/N: 226409J DCN 13466