



Series AP5104

LVDT DIN-rail Amplifier



Description

The Series AP5104 DIN-rail Amplifier is a high reliability conditioner for measurement of displacement with an LVDT (linear variable differential transformer). It can be used with 4, 5, and 6-wire LVDT's. The AP5104 provides regulated AC excitation with remote sensing for applications which may require cable lengths greater than 20 feet. The analog output of the AP5104 DIN mount signal conditioner can be switched using the front panel controls for ± 5 Vdc, ± 10 Vdc, or 4-20mA. These analog outputs are filtered using a low-pass active filter that removes unwanted high-frequency measurement-signal components and thus eliminates aliasing errors. The Series AP5104 is designed for a very wide range of signals for 16 to 1600 mV/V full scale. The AP5104 has a phase shift adjustment feature used to synchronize primary and secondary phase shift due to LVDT winding inductance and cabling. LVDT setup and calibration is simplified because configuration and all adjustments are performed through the front panel controls. There is no need for the user to open the DIN enclosure for jumper or switch settings changes. The DIN mount housing is designed with non-removable screw terminals.

Standard Features

- Regulated, Remotely Sensed AC Excitation
- DIN Mount Construction
- Filtered Analog Outputs of ± 5 Vdc, ± 10 Vdc, 4-20 mA, 4-12-20 mA
- Switch Selectable Outputs Using Front Panel Controls
- Auto Phase and Manual Phase Selection
- $\pm 100\%$ Zero Offset Adjustment
- Noise Free Outputs
- 16 to 1600 mV/V Signals
- Phase Shift Adjustment
- Over-Range and Power Indicators

Series AP5104

Specifications

Baseline Configuration Specs Represented.
Modifications Encouraged - See Below
Custom Designs Available

Performance

Transducer Types

Virtually any variable transformer transducer, including 4-, 5-, and 6-wire LVDT's and 3- and 5-wire Variable Reluctance Transducers (Variable Reluctance Transducers, requires external bridge resistors 1k, 1% 25 ppm or better).

Input Ranges (Nominal, Full-Scale)

Low Range: 16 to 160 mV/V
High Range: 160 to 1600 mV/V.

Front Panel Switch Settings

	Left	Right
Output Mode	Current	Voltage
Voltage Level	10 Vdc	5 Vdc
Current Level	4-12-20 mA	4-20 mA
Filter Setting	1 kHz	100 Hz
Filter Setting	10 Hz	100 Hz
Sync mode	Slave	Master
Zero Adjust	Extended	Normal
Sensor mv/V		
Range	Low	High
Phase Mode	Manual	Auto

Mechanical Characteristics

Housing

DIN mount housing; non-removable screw terminals.

Dimensions

4.7" deep x 0.9" wide x 3.9" high.

Electrical Characteristics

Power Requirements

11- 28 VDC, 2 watts max.

Normal-Mode Range

5 V rms.

Excitation Frequency

5.00 kHz .

Excitation Voltage

Nominal 2.77 Vac rms.

Input Impedance (Differential)

200 k ohm.

Offset

vs. temperature: ± 30 ppm/ $^{\circ}$ C

vs. time: ± 10 ppm/month

Gain Accuracy

Limited only by calibration accuracy.

Gain Stability

vs. temperature: ± 30 ppm/ $^{\circ}$ C

vs. time: ± 10 ppm/month

Analog Filters

Input Ranges (Nominal, Full-Scale):

Low pass; Three-pole modified butterworth selectable at 10, 100, or 1000 Hz.

Electrical Characteristics

Analog Outputs

Filtered ± 0 to 5 Vdc or ± 0 to 10 Vdc or 4-20 mA Selectable via front panel - 20 % over-range in voltage mode

Status Indicator Lights

Power and analog over-range.

Environmental Characteristics

Operating Temperature Range

14 $^{\circ}$ F to 158 $^{\circ}$ F.

Operating Relative Humidity

5% to 95%, noncondensing.

Connection and Adjustment

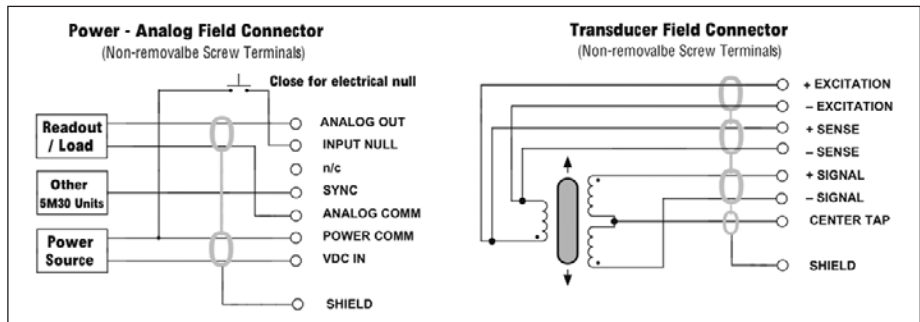

Modifications and Warranty

MODIFICATIONS: We realize transducer applications vary greatly and as such our designs are flexible. Choice of pressure port, electrical termination, material compatibility and performance characteristics are a few of the many options available. Specifications on this datasheet represent the standard configuration only. Product and company names listed are trademarks of their respective companies. Specifications subject to change without notice.

WARRANTY: Stellar Technology warrants that its product shall be free from defective workmanship and/or material for a twelve month period from the date of shipment, provided that Stellar Technology's obligation hereunder shall be limited to correcting any defective material FOB our factory. No allowance will be made for any expenses incurred for correcting any defective workmanship and/or material without written consent by Stellar Technology. This warranty is in lieu of all other warranties expressed or implied.



ISO 9001/AS9100

Due to the nature of technology, changes are inevitable. For latest technical specifications, see our website.

237 Commerce Drive • Amherst, NY 14228 • USA

Tel: 716.250.1900 • Fax: 716.250.1909

Web: stellartech.com • Email: info@stellartech.com

Copyright © 2015 STI • All Rights Reserved
Datasheet P/N: 234191C DCN 13447