

Series APD4059

For Load Cells/Pressure Transducer Transmitters.
Field Rangeable, with Calibration Resistor



Standard Features

- Use Internal or External Calibration Resistor
- Sense Lead Compensation
- Easy to Cancel or Tare Out Deadweights
- Drive up to Four 350 Ω Bridges
- Non-Interactive Zero and Span
- One Minute Setup for Hundreds of I/O Ranges
- Removable Plugs for Faster Installation
- Full 3-Way Input/Output/Power Isolation
- Variable Brightness I/O Status LEDs
- Adjustable Excitation Power Supply

Optional Features

- 10 millisecond response time typical (100 Hz)
- Conformal coating for moisture resistance

Applications

- Load Cell Weighing Systems and Scales
- Strain Gage Pressure Sensors and Transducers
- Tanks, Scales, Extruder Melt Pressure, Crane Loads

Range Setup and Wiring

Range Selection

It is generally easier to select ranges before installing the module on the DIN rail. The tables below list available settings and ranges.

The table on the next page is used for offsets. The module side label lists common ranges. See the model/serial number label if a custom range was specified.

Rotary switches and a slide switches on the side of the module are used to select input and output ranges to match your application.

- Switch A: Excitation voltage
- Switch B: Input range
- Switch C: Input offset (see table on next page)
- Switch D: Output range
- Switch E: Set to "V" for voltage output or "I" for current output

Determine how much output in millivolts the load cell will produce at full load. Multiply the manufacturer's mV/V sensitivity specification by the applied excitation voltage.

For example, a load cell rated for 3 mV/V sensitivity using 10 VDC excitation will produce an output of 0 to 30 mV for load variations from 0 to 100%.

3 mV/V sensitivity X 10 VDC excitation = 30 mV range

Excitation Voltage Setup

Refer to the sensor manufacturer's recommendations to determine what excitation voltage to use.

Set Excitation rotary switch A to desired excitation voltage. After installation the excitation fine adjust potentiometer may be used to precisely trim this voltage, if desired.

Excitation	Switch A
10 V	A
9 V	9
8 V	8
7 V	7
6 V	6
5 V	5
4 V	4
3 V	3
2 V	2
1 V	1
0 V	0

I/O Range Selection B, C, D, E

- From the table below, find the rotary switch combination that matches your I/O ranges and set rotary switches B, C, and D.
- Set switch E to "V" for voltage output or "I" for current output.
- For ranges that fall between the listed ranges use the next highest setting and trim the output signal with the zero and span potentiometers as described in the Calibration section.

Output	0-1 V	0-2 V	0-4 V	1-5 V	0-5 V	0-8 V	2-10 V	0-10 V	±5 V	±10 V	0-2 mA	0-4 mA	0-8 mA	2-10 mA	0-10 mA	0-16 mA	4-20 mA	0-20 mA
Switches	BCDE	BCDE	BCDE	BCDE	BCDE	BCDE	BCDE	BCDE	BCDE	BCDE	BCDE	BCDE	BCDE	BCDE	BCDE	BCDE	BCDE	BCDE
0-5 mV	200V	208V	201V	206V	209V	202V	207V	203V	204V	205V	200I	208I	201I	206I	209I	202I	207I	203I
0-10 mV	A00V	A08V	A01V	A06V	A09V	A02V	A07V	A03V	A04V	A05V	A00I	A08I	A01I	A06I	A09I	A02I	A07I	A03I
0-20 mV	300V	308V	301V	306V	309V	302V	307V	303V	304V	305V	300I	308I	301I	306I	309I	302I	307I	303I
0-25 mV	600V	608V	601V	606V	609V	602V	607V	603V	604V	605V	600I	608I	601I	606I	609I	602I	607I	603I
0-30 mV	E00V	E08V	E01V	E06V	E09V	E02V	E07V	E03V	E04V	E05V	E00I	E08I	E01I	E06I	E09I	E02I	E07I	E03I
0-40 mV	B00V	B08V	B01V	B06V	B09V	B02V	B07V	B03V	B04V	B05V	B00I	B08I	B01I	B06I	B09I	B02I	B07I	B03I
0-50 mV	000V	008V	001V	006V	009V	002V	007V	003V	004V	005V	000I	008I	001I	006I	009I	002I	007I	003I
0-100 mV	800V	808V	801V	806V	809V	802V	807V	803V	804V	805V	800I	808I	801I	806I	809I	802I	807I	803I
0-120 mV	F00V	F08V	F01V	F06V	F09V	F02V	F07V	F03V	F04V	F05V	F00I	F08I	F01I	F06I	F09I	F02I	F07I	F03I
0-200 mV	100V	108V	101V	106V	109V	102V	107V	103V	104V	105V	100I	108I	101I	106I	109I	102I	107I	103I
0-250 mV	400V	408V	401V	406V	409V	402V	407V	403V	404V	405V	400I	408I	401I	406I	409I	402I	407I	403I
0-300 mV	C00V	C08V	C01V	C06V	C09V	C02V	C07V	C03V	C04V	C05V	C00I	C08I	C01I	C06I	C09I	C02I	C07I	C03I
0-400 mV	900V	908V	901V	906V	909V	902V	907V	903V	904V	905V	900I	908I	901I	906I	909I	902I	907I	903I

Electrical Connections and Installation

WARNING! All wiring must be performed by a qualified electrician or instrumentation engineer. See diagram for terminal designations and wiring examples. Consult factory for assistance.

Avoid shock hazards! Turn signal input, output, and power off before connecting or disconnecting wiring. Connect power last.

Check white model/serial number label for module operating voltage to make sure it matches available power.

Module Power Terminals

When using DC power, either polarity is acceptable, but for consistency with similar API products, positive (+) can be wired to terminal 13 and negative (-) can be wired to terminal 16. Connect I/O wiring before power wiring.

Signal Input Terminals

Refer to strain gauge manufacturer's data sheet for wire colorcoding. Polarity must be observed when connecting inputs.

CAUTION: Never short the excitation leads together. This will cause internal damage to the module.

A five- or six-lead bridge has one or two sense leads respectively. Sense leads allow the APD 4059 to compensate for leadwire resistance effects. Connect the sense leads if used. Polarity must be observed.

If no sense lead is used, jumper sense (+) terminal 6 and excitation (+) 12.

Final trim adjustment should be done after all connections are made.

Signal Output Terminals

Polarity must be observed when connecting the signal output. If your device accepts a current input, determine if it provides power to the current loop or if it must be powered by the APD module. Use a multi-meter to check for voltage at the device's input terminals. Typical voltage may be 9-24 VDC.

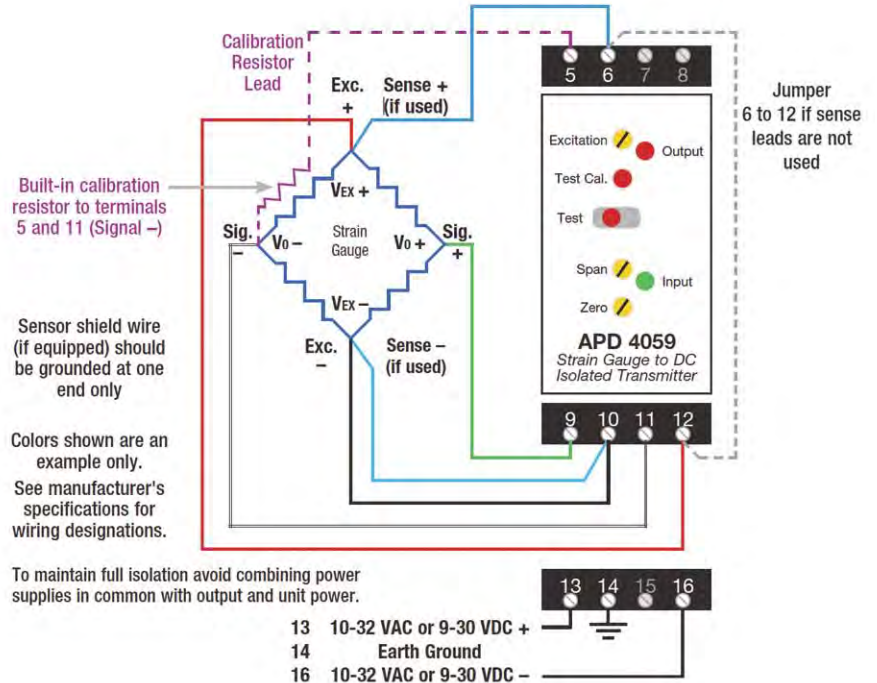
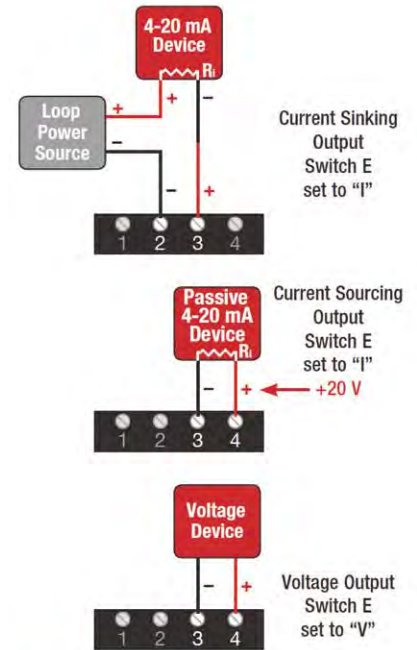

Type of Device for Output	- Terminal	+ Terminal
Measuring/recording device accepts a mA (current) input and provides power to the current loop.	2 (-)	3 (+) switch E set to "I"
Measuring/recording device accepts a mA (current) input and the input is unpowered or passive. APD module provides the loop power.	3 (-)	4 (+20 V) switch E set to "I"
Measuring/recording device accepts a voltage input.	3 (-)	4 (+) switch E set to "V"



Strain Gauge to DC Isolated Transmitter



1. Set Switch A for desired Excitation Voltage.
2. Set Switches B/C/D for desired Input / Output ranges.
3. Set Switch E for Voltage or Current as required.
4. Set Excitation / Zero / Span / Test Cal. Controls

For more Details and Instructions see Data Sheet

Connections	
Term. #	Signal
3	Sig. Out -
4	Sig. Out +
6	Sense Lead
9	Sig. Input +
10	Exc. -
11	Sig. Input -
12	Exc. +
13	Power +
16	Power -

Excitation Switch	
Voltage	Position
10V	A
9V	9
8V	8
7V	7
6V	6
5V	5
4V	4
3V	3
2V	2
1V	1
0V	0

INPUT	OUTPUT									
	0-5 mV	0-10 mV	0-20 mV	0-25 mV	0-30 mV	0-40 mV	0-50 mV	0-100 mV	0-200 mV	0-250 mV
Rotary Switches	BCD	BCD	BCD	BCD	BCD	BCD	BCD	BCD	BCD	BCD
0-1V	200	A00	300	600	E00	B00	000	600	100	400
0-5V	209	A09	309	609	E09	B09	009	609	109	409
1-5V	206	A06	306	606	E06	B06	006	606	106	406
+/-5V	204	A04	304	604	E04	B04	004	604	104	404
0-10V	203	A03	303	603	E03	B03	003	603	103	403
+/-10V	205	A05	305	605	E05	B05	005	605	105	405
4-20mA	207	A07	307	607	E07	B07	007	607	107	407

EXAMPLE: 0-30mV IN, 4-20mA OUT, CODE 0E7. Set switch 'B' to E, 'C' to 0, 'D' to 7

Calibration, Operation

Calibration

The Zero, Span, and Excitation potentiometers are used to calibrate the output. This calibration procedure does not account for offsets or tare weights. If your system has an offset, tare weight or deadweight, refer to the Offset Switch procedure.

To achieve optimum results, the system should be calibrated using an accurate bridge simulator, pressure calibrator, or calibration weights depending on the application.

1. Apply power to the module and allow a minimum 20 minute warm up time.
2. Using an accurate voltmeter across terminals 10 and 12, adjust the excitation voltage potentiometer for the exact voltage desired.
3. Provide an input to the module equal to zero or the minimum input required for the application.
4. Using an accurate measurement device for the module output, adjust the Zero potentiometer for the exact minimum output signal desired. The Zero control should only be adjusted when the input signal is at its minimum.
5. Set the input at maximum, and then adjust the Span pot for the exact maximum output desired. The Span control should only be adjusted when the input signal is at its maximum.

Using Offset Switch C

Offset switch C allows canceling or taring of non-zero deadweights or other sensor offsets such as:

- Compensate for tare weights or scale deadweight to get zero output when a load is on the platform.
- Compensate for low-output sensors (e.g., less than 1 mV/V) that may have large zero offsets. Switch C can realign the zero control so it has enough range to produce the desired zero output.
- Raising the offset to allow calibration of bipolar sensors such as ± 10 mV.
- Lowering the offset to compensate for elevated input ranges such as 10-20 mV.

1. Switch C does not interact with any other switch and is the only switch needed to correct zero offsets. Its only purpose is to adjust or cancel effects of the low end of the input range not corresponding nominally to 0 mV. Setting this switch to "0" results in no offset.

2. To RAISE the output zero, rotate switch C from "1" thru "7", until the Zero control can be set for your application.

3. To LOWER the output zero, rotate switch C from "9" thru "F", until the Zero control can be set for your application.

4. After all switches are set, repeat the calibration procedure as described above.

Offset % of Span	Switch C
105%	7
90%	6
75%	5
60%	4
45%	3
30%	2
15%	1
0%	0
-15%	9
-30%	A
-45%	B
-60%	C
-75%	D
-90%	E
-105%	F

Changing the Internal Calibration Resistor

A shunt resistor is installed internally in the APD 4059. The resistance was specified when the APD 4059 was ordered and should match what is specified by the transducer manufacturer.

The calibration resistor can be changed in the field if required by following the procedure below.

1. Remove all power from the APD4059, unplug all connectors, and remove unit from DIN rail.
2. Using a small flat-blade screwdriver remove the front panel as shown.
3. Note the locations of the seven tabs attaching the side cover.
4. Using a small flat-blade screwdriver gently pry the tab ends away from the housing. Start with the large tab at the rear of the unit, and work towards the front while gently pulling up on the side cover.
5. When all tabs are unlatched, remove the side cover.
6. To remove the calibration resistor, pull it out of its holder. A replacement calibration resistor should have the leads cut and bent like the original one.
7. Align the side cover and snap into place making sure all seven tabs are engaged. Snap front cover back into place. Reinstall unit.

Calibration with Internal Calibration Resistor

The sensor manufacturer should provide the percentage of fullscale output for the transducer when using the internal resistor for calibration.

1. With the APD4059 powered and the transducer at operating temperature, adjust the zero pot located on top of the APD4059 for a zero or low-end output (for example, 4 mA for a 4-20 mA output).
2. The zero pot may also be adjusted for a zero reading on the output display instrumentation, e.g. control system or process indicator. Adjusting the zero pot this way eliminates calibration errors in the display instrumentation.
3. Set the APD4059 TEST toggle switch to the TEST position. The internal shunt resistor is switched into the circuit to unbalance the bridge.
4. Adjust the span pot to the for an 80% FS output or 80% reading on the process indicator.
5. Return the TEST switch to the opposite position and readjust the zero pot if necessary.

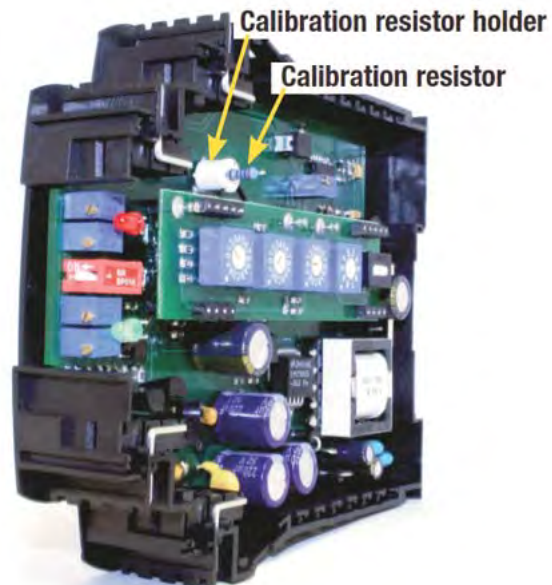

External Calibration Resistor

Refer to the load cell manufacturer's specifications and the wiring diagram on previous page when connecting a transducer with its own internal calibration resistor.

The transducer's calibration resistor wires are connected to terminals 5 and 11 on the APD4059.

With this type of transducer no internal calibration resistor should be installed.

The sensor manufacturer should provide the percentage of fullscale output for the transducer when using the transducer's internal calibration resistor.

1. With the APD4059 powered and the transducer at operating temperature, adjust the zero pot located on top of the APD4059 for a zero or low-end output, e.g. 4 mA (assuming the selected output is 4-20 mA).
2. The zero pot may also be adjusted for a zero reading on the output display instrumentation, e.g. control system or process indicator. Adjusting the zero pot this way eliminates calibration errors in the display instrumentation.
3. Set the APD4059 TEST toggle switch to the TEST position. The transducer's shunt resistor is switched into the circuit to unbalance the bridge.
4. Adjust the span pot to the for an 80% FS output or 80% reading on the process indicator, or per the manufacturer's percentage of FS output.
5. Return the TEST switch to the opposite position and readjust the zero pot if necessary.

Operation

Strain gauges and load cells are normally passive devices that are commonly referred to as "bridges" due to their four-resistor Wheatstone bridge configuration. These sensors require a precise excitation source to produce an output that is directly proportional to the load, pressure, etc. that is applied to the sensor.

The exact output of the sensor (measured in millivolts) is determined by the sensitivity of the sensor (mV/V) and the excitation voltage applied.

An additional input, the sense lead, monitors the voltage drop in the sensor leads and automatically compensates the excitation voltage at the module in order to maintain a constant excitation voltage at the sensor.

The APD4059 provides the excitation voltage to the sensors and receives the resulting millivolt signal in return. This input signal is filtered and amplified, then offset, if required, and passed to the output stage. Depending on the output configuration selected, a DC voltage or current output is generated.

GREEN LoopTracker® Input LED – Provides a visual indication that a signal is being sensed by the input circuitry of the module. It also indicates the input signal level by changing in intensity as the process changes from minimum to maximum. If the LED fails to illuminate, or fails to change in intensity as the process changes, this may indicate a problem with module power or signal input wiring.

RED LoopTracker Output LED – Provides a visual indication that the output signal is functioning. It becomes brighter as the input and the corresponding output change from minimum to maximum.

For current outputs, the RED LED will only light if the output loop current path is complete. For either current or voltage outputs, failure to illuminate or a failure to change in intensity as the process changes may indicate a problem with the module power or signal output wiring.

Installation, Diagnostics, Load Cell Information

Installation Precautions

WARNING! Avoid shock hazards! Turn signal input, output, and power off before connecting or disconnecting wiring, or removing or installing module.

Installation

The housing clips to a standard 35 mm DIN rail. The housing is IP40 rated and should be mounted inside a panel or enclosure.

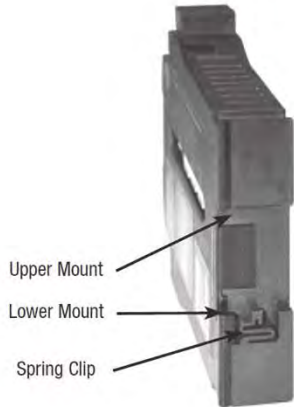

Installation



1. Tilt front of module downward and position against DIN rail.
2. Clip Lower Mount to bottom edge of DIN rail.



3. Push front of module upward until Upper Mount snaps into place.

Removal

Avoid shock hazards! Turn signal input, output, and power off before removing module.

1. Push up on bottom back of module.
2. Tilt front of module downward to release Upper Mount from top edge of DIN rail.
3. The module can now be removed from the DIN rail.

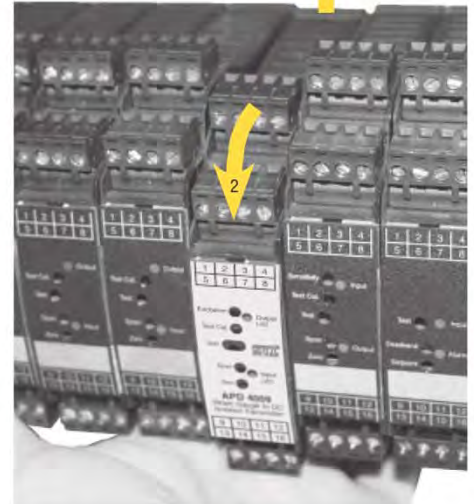

Diagnostic Voltage Measurements

Using a meter with at least 10 megaohm input impedance, measure the voltage coming from the strain gauge at the locations shown. Sensitivity is measured in mV/V.

Positive Meter Lead	Negative Meter Lead	Meter Reading No pressure/load	Meter Reading Full pressure/load
+ Exc.	- Exc.	Excitation Voltage	Excitation Voltage
+ Sig.	- Exc.	+ 1/2 Excitation Voltage	1/2 Excitation Voltage + (1/2 x Excitation Voltage x Sensitivity)
- Sig.	- Exc.	+ 1/2 Excitation Voltage	1/2 Excitation Voltage - (1/2 x Excitation Voltage x Sensitivity)
+ Sig.	- Sig.	Zero Volts	Excitation Voltage x Sensitivity

WARRANTY: Stellar Technology warrants that its product shall be free from defective workmanship and/or material for a twelve month period from the date of shipment, provided that Stellar Technology's obligation hereunder shall be limited to correcting any defective material FOB our factory. No allowance will be made for any expenses incurred for correcting any defective workmanship and/or material without written consent by Stellar Technology. This warranty is in lieu of all other warranties expressed or implied.

ISO 9001



237 Commerce Drive • Amherst, NY 14228 • USA
Tel: 716.250.1900 • **Fax:** 716.250.1909
Email: info@stellartech.com • **Web:** stellartech.com