

Series PNC760

Fatigue Rated, Precision Pancake Load Cell

PNC760

Standard Features

- Tension / Compression
- High Strength Steel
- Barometrically Compensated
- Accuracy to 0.03%
- Fatigue Rated
- 100 million Cycle life
- 0.25% Off-Axis Sensitivity
- -65° to 250° F Operation
- mV/V Operation



Standard Specifications

Performance

Capacities	250, 500, 1000, 2500, 5000, 12.5K, 25K, 50K, 100K lbs.
Output	2 mV/V nominal.
Accuracy	Up to 0.03% FSO BFSL (See Table).
Compensated Temperature Range	15°F to 115°F.
Operating Temperature Range	-65°F to 250°F.
Temperature Effect on Zero	0.0008% FSO/ F.
Temperature Effect on Span	0.0008% Reading/°F.
Creep, in 30 min	0.025% Load.
Off-Axis Sensitivity	0.25% / in.
Zero Balance	1% FSO.
Bridge Resistance	350 Ohms nominal.

Mechanical Characteristics

Calibration	5 Points (0, 50%, 100%, 50%, 0) Tension/Compression.
Static Overload Capacity	200% FSO.
Construction	Environmentally sealed and painted high strength steel or aluminum (see table).

Electrical Characteristics

Excitation	10 Vdc or Vac.
Maximum Excitation	20Vdc or Vac.
Insulation Resistance	Greater than 5000 megaohms at 50 Vdc at 70°F.
Connector	PTIH-10-6P, Stainless steel with Gold Plated Pins.
Connector Pins	A +EXE D - EXE B +SIG E NC C - SIG F NC

Series PNC760 Specifications

Baseline Configuration Specs Represented.
Modifications Encouraged - See Below

Dimensions (inches)

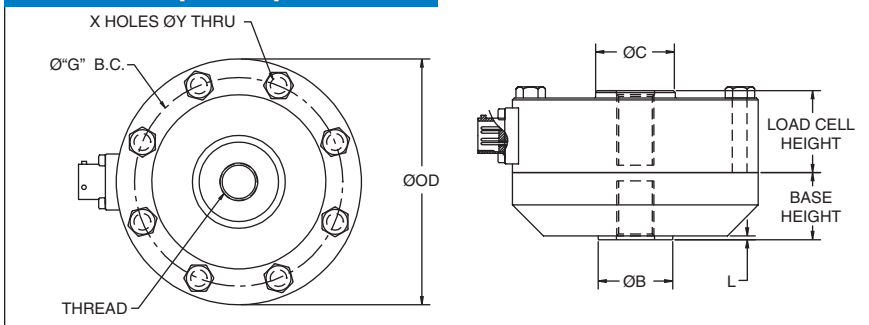

Capacity (lbs.)	ØOD	Thread	Height	X	ØY	ØG	ØC	Base Height	ØB	Material
250, 500, 1000	4.13	5/8-18 UNF	1.38	8	0.28	3.50	1.34	1.13	1.25	Aluminum
2.5K, 5K	4.13	5/8-18 UNF	1.38	8	0.28	3.50	1.34	1.13	1.25	Steel
12.5K, 25K	6.00	1 1/4-12 UN	1.75	12	0.41	5.13	2.65	1.75	2.25	Steel
50K	8.00	1 3/4-12 UN	2.50	16	0.53	6.50	3.76	2.00	3.00	Steel
75K, 100K	9.00	2 1/2-12 UN	3.00	16	0.66	7.88	4.00	2.75	4.00	Steel

MECHANICAL CHARACTERISTICS AND RATINGS

CAPACITY (LBS)	250, 500, 1K	2.5K, 5K	12.5K, 25K	50K	75K, 100K
Accuracy (%FSO BFSL)	0.03	0.04	0.05	0.05	0.06
Linearity (%FSO)	0.04	0.04	0.05	0.05	0.05
Hysteresis (%FSO)	0.03	0.04	0.05	0.05	0.06
Repeatability (%FSO)	0.02	0.02	0.02	0.02	0.02
Deflection @ FSO	0.001	0.001	0.001	0.002	0.002

Available Options

Threads	Metric or Custom.
Output	3mV/V, 4mV/V, Custom. Standardized output.
Dimensions	Custom dimensions welcome.
Compensated Temperature Ranges	-65° to 400° F.
Operating Temperature Ranges	-65° to 400° F.
Calibration	Additional calibration points (in addition to standard points) available (Consult Factory). Special and custom calibrations available (Consult Factory)
Amplifiers	Internal and/or In-Line (Consult Factory). • Analog (4-20 mA; 0-5 Vdc; 0-10 Vdc). • Digital (RS-232; RS-485; CANbus; MODbus).
Multiple Bridges	Dual and Triple bridges available.
Calibration Range	Special full scale ranges (Example: 75 lb).
Cables and Cable Length	For Cable types available, consult factory. Specify Cable length.
Cable Connector	Add a connector to the end of the cable. Consult factory for available connectors.
Connectors	Many connectors available (PT04, MS3102, etc.) Consult factory Orientation: Any orientation (radial standard, tangential, up or down or custom). Connector guards.
Overload Protection	Compression. Overload stops take up to 10X F.S. Consult factory.
Shock and Vibration	All Stellar PNC740 load cells come standard with shock and vibration protection.
Custom Options	Other customer requested options welcome.



0539

Notes, Modifications, Warranty

NOTES: When using a load cell the user must consider load ratings and fatigue life for long term use and structural integrity. Critical loading applications, especially overhead loading, must always be designed with safety redundant load paths. MODIFICATIONS: We realize load cell applications vary greatly and as such our designs are flexible. Specifications subject to change without notice.

WARRANTY: Stellar Technology warrants that its product shall be free from defective workmanship and/or material for a twelve month period from the date of shipment, provided that Stellar Technology's obligation hereunder shall be limited to correcting any defective material FOB our factory. No allowance will be made for any expenses incurred for correcting any defective workmanship and/or material without written consent by Stellar Technology. This warranty is in lieu of all other warranties expressed or implied.



Due to the nature of technology, changes are inevitable. For latest technical specifications, see our website.