

# Series DT190

Differential Pressure Transducers

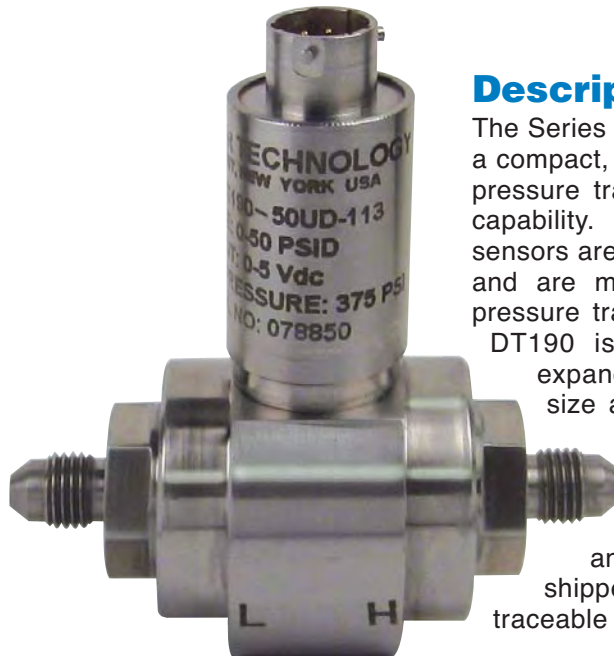

## Description

The Series DT190 differential pressure transducer is a compact, reliable, and rugged, wet-wet differential pressure transducer with high differential pressure capability. The Series DT190 differential pressure sensors are constructed of all welded stainless steel and are more robust than fluid filled differential pressure transducers with bolted construction. The DT190 is free of any fluid fill and thus has expanded temperature ranges. The smaller size and all welded construction make these units ideal for applications exhibiting higher levels of shock and vibration. Other key design features include long term stability, and both bidirectional and unidirectional outputs. Each DT190 is shipped with a 15 point calibration record traceable to NIST as standard.

## Standard Features

- All Welded Stainless Steel
- Compact Size
- Wide Temperature Capabilities
- No Fluid Fill
- Ranges From 50 to 40,000 psid
- Unidirectional and Bidirectional Operation
- 0.25% Accuracy
- 15 Point Calibration Record Traceable to NIST

## Optional Features

- Customer Specified Electrical Termination
- Customer Specified Pressure Ports
- Submersible Versions
- Alternative Materials
- Special Calibrations

**DT190**

# Series DT190 Specifications

Baseline Configuration Specs Represented.  
Modifications Encouraged - See Below  
Custom Designs Available

## Performance

### Static Accuracy

± 0.25% FSO by BFSL.

### Resolution

Infinite

### Thermal Error

< ± 0.020% FS/°F typical.

### Input / Output Resistance

350 ohms (nominal).

### Insulation Resistance

> 100 megohms at 50 Vdc at 70°F.

### Zero Balance

± 1% FSO at 70°F.

### Full Scale Output

1.5 ± 0.008 mV/V FSO at 70°F.

### Zero Shift with Line Pressure

± 1% FSO at 70°F.

## Mechanical Characteristics

### Standard Ranges

50, 75, 100, 150, 250, 500, 1000,  
2000, 5000, 10,000, 30,000 to 40,000  
PSID. Bidirectional or Unidirectional.

### Maximum Line Pressure

1.5X differential pressure range.

### Safe Overload Pressure

Safe overload pressure = maximum line  
pressure on either side.

(note: when selecting a DT190, it is  
important to state what the maximum  
pressure is on either side.)

### Operating Media

Fluids and gases compatible with 17-4  
stainless steel. (Inconel and other  
materials optional).

### Pressure Fitting

(For line pressures 50 psi thru 10,000 psi)

1/4" NPT Male (Standard).

1/4" NPT Female (No charge option).

7/16"-20 per AS4395E4 / MS33656-4

(Male) – (No charge option).

7/16"-20 per AS5202E4 / MS33649-4

(Female) – (No charge option).

(For line pressures 15,000 psi thru  
60,000 psi)

AE F250-C, 9/16"-18 UNF, (Female) or  
equivalent (Standard).

For additional pressure fittings please  
consult factory.

### Enclosure

Body and pressure cavity of  
stainless steel, environmentally sealed.

### Weight

Approximately 16 oz.

## Electrical Characteristics

### Excitation

10 Vdc recommended, 15 Vdc max.

### Electrical Termination

PTIH-10-6P stainless steel connector or  
equivalent.

Optional electrical terminations available.

### Wiring

PIN A (+) Excitation

PIN B (+) Signal

PIN C (-) Signal

PIN D (-) Excitation

PIN E, F No Connection

Shunt Available

Standard configuration shown.

Options available.

## Environmental Characteristics

### Compensated Temperature Range

+30°F to +130°F.

Options available.

### Operating Temperature Range

-100°F to +300°F.

## Dimensions (inches)

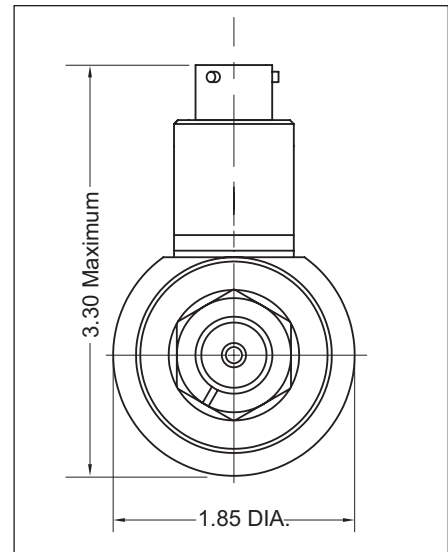

CE  
0539

MODIFICATIONS: We realize transducer applications vary greatly and as such our designs are flexible. Choice of pressure port, electrical termination, material compatibility and performance characteristics are a few of the many options available. Specifications on this datasheet represent the standard configuration only. Product and company names listed are trademarks of their respective companies. Specifications subject to change without notice.

WARRANTY: Stellar Technology warrants that its product shall be free from defective workmanship and/or material for a twelve month period from the date of shipment, provided that Stellar Technology's obligation hereunder shall be limited to correcting any defective material FOB our factory. No allowance will be made for any expenses incurred for correcting any defective workmanship and/or material without written consent by Stellar Technology. This warranty is in lieu of all other warranties expressed or implied.

Find More Information at:  
[stellartech.com](http://stellartech.com)

Due to the nature of technology, changes are inevitable. For latest technical specifications, see our website.

237 Commerce Drive • Amherst, NY 14228 • USA

Tel: 716.250.1900 • Fax: 716.250.1909

Email: [info@stellartech.com](mailto:info@stellartech.com)

ISO 9001:2000

**STI**  
STELLAR TECHNOLOGY