

Coiled Tubing Load Cell

Intrinsically Safe Coiled Tubing Injector Load Cell



Standard Features

- Standard Ranges from 20,000 lbs. to 120,000 lbs.
- Tension and Compression
- 4-20 mA output
- ATEX and CSA Approved for Intrinsic Safety
- All Welded Stainless Steel
- -65°F to +185°F Operating Temperature
- Extra Robust Electrical Connectors
- Hermetically Sealed
- Shock and Vibration Resistant
- 11 Point Calibration Record Traceable to NIST

Optional Features

- Customer Specified Center Hole and Mounting Holes
- Customer Specified Electrical Termination
- Overload Stops
- Metric Versions
- -65°F to +250°F Operating Temperature
- Special Calibrations

Description

Stellar Technology's coiled tubing injector load cells are low profile, tension and compression, pancake designs with 4-20 mA output. This CT load cell is both ATEX and CSA certified for intrinsic safety. This load cell transmitter incorporates a threaded-through center hole with dual diaphragms which reduces off-axis sensitivity, increases rigidity, and improves accuracy. STI's coiled tubing load cells are constructed of all welded stainless steel to meet the demanding requirements of both onshore and offshore oil and gas applications. Features include shock and vibration protection as well as hermetically sealed stainless steel connectors. These load cells can be configured to replace existing hydraulic load cells or other types of electronic load cells without redesigning the injector. Tension and compression setup and calibrations are per the customer's requirements. Each unit is shipped with both 5 point tension and 5 point compression calibration records traceable to NIST as standard. (See Series LPD990 for Injector Head Load Pins)

Performance

Standard Ranges

20,000 lbs to 120,000 lbs.

Output

4-20 mA.

Accuracy

0.10% BFSL.

Temperature Effect on Zero

0.005% FSO/° F (0.009% FSO/° C).

Temperature Effect on Span

0.005% Reading/° F (0.009% Reading/° C).

Environmental Characteristics

Operating Temperature Range

-65° F to 250° F (-54°C to 120°C).

Compensated Temperature Range

-40° F to 200° F (-40°C to 95°C).
(-65°F to 250°F optional.)

Coiled Tubing

Coiled Tubing Load Cell Specifications

Baseline Configuration Specs Represented.
Modifications Encouraged - See Below
Custom Designs Available

Dimensions (inches)

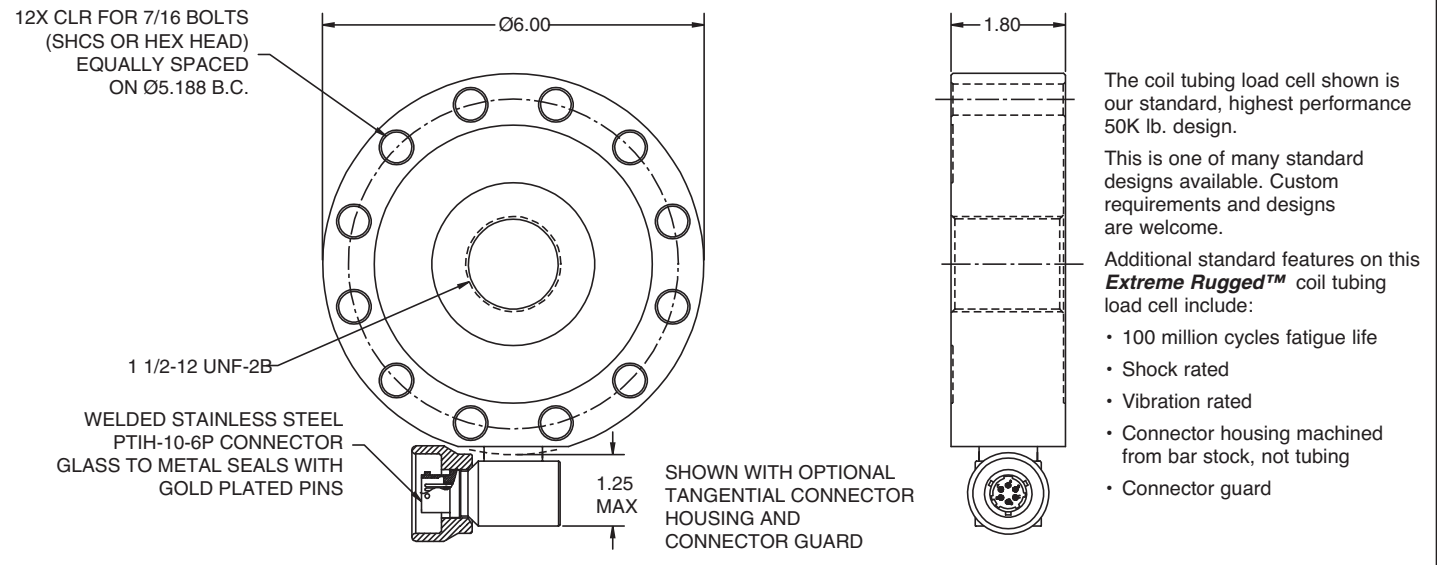

Certifications



YOM: 05/2007
I.S. Class I, Div 1, Group A,B,C,D,T3C
U_{max}=36Vdc, I_{max}=100mAdc,
C_i=24nF, L_i=2.7uH
Per Installation DWG 217872



II 1 G EEx ia IIC
(Tamb. -40 to 85°C)
U_{max}=28Vdc, I_{max}=93mAdc,
C_i=11nF, L_i=0mH
DNV-2003-OSL-ATEX-0259
Per Installation DWG 220218



Mechanical Characteristics

Static Overload Without Damage

150% FSO.

Calibration

Standard calibration is 5 pts
(0, 50%, 100%, 50%, 0) tension and
compression.

Material

Welded stainless steel.

Electrical Characteristics

Excitation

9-36 VDC.

Output

4-20 mA.

Insulation Resistance

Greater than 100 megohms
at 50 Vdc.

Electrical Termination

Hermetic glass to metal sealed
connector.



NOTES: When using a load cell the user must consider load ratings and fatigue life for long term use and structural integrity. Critical loading applications, especially overhead loading, must always be designed with safety redundant load paths. MODIFICATIONS: We realize load cell applications vary greatly and as such our designs are flexible. Specifications subject to change without notice.

WARRANTY: Stellar Technology warrants that its product shall be free from defective workmanship and/or material for a twelve month period from the date of shipment, provided that Stellar Technology's obligation hereunder shall be limited to correcting any defective material FOB our factory. No allowance will be made for any expenses incurred for correcting any defective workmanship and/or material without written consent by Stellar Technology. This warranty is in lieu of all other warranties expressed or implied.

Find More Information at:
stellartech.com

Due to the nature of technology, changes are inevitable. For latest technical specifications, see our website.

237 Commerce Drive • Amherst, NY 14228 • USA

Tel: 716.250.1900 • Fax: 716.250.1909

Email: info@stellartech.com

Copyright © Stellar Technology Incorporated • All Rights Reserved
Datasheet P/N: 226758D

