

# Series CNR960

High Capacity/High Accuracy

Tension and Compression Canister Load Cell



## Description

The Series CNR960 tension / compression canister style load cells are designed specifically for high capacity and high accuracy test and measurement applications requiring long fatigue life combined with high resistance to the effects of extraneous bending and off-axis loading. The uniquely engineered CNR960 Series load cells have a minimum deflection resulting in fast frequency response. Constructed of electroless nickel plated carbon steel, all CNR960 load cells are manufactured to be shock and vibration resistant. Each unit is shipped with an 10 point calibration (5 points in both tension and compression) record traceable to NIST as standard.

*(See data sheet for Series CNR960XX for high level output version)*

## Standard Features

- Tension and Compression
- Load Ranges to 2 Million Pounds
- High Static Accuracy
- High Fatigue Life
- High Immunity to Off-Axis Loading
- Center Thread Mount or Circular Bolt Mount

## Optional Features

- Dual Bridge Configurations
- Customer Specified Electrical Termination
- Special Calibrations
- Metric Threads
- Expanded Temperature Compensation Ranges

## Performance

### Standard Ranges

25K, 50K, 100K, 150K, 200K, 300K, 500K, 800K, 1000K, 2000K lbf.

### Static Accuracy

Linearity:  $\pm 0.2\%$  FSO.  
Hysteresis:  $\pm 0.2\%$  FSO.  
Repeatability:  $\pm 0.05\%$  FSO.

### Temperature Effect on Zero

$\pm 0.003\%$  FSO/ $^{\circ}$ F.

### Temperature Effect on Span

$\pm 0.003\%$  Reading/ $^{\circ}$ F.

### Zero Balance

$\pm 1\%$  FSO at 70 $^{\circ}$ F.

### Electrical Outputs

2 mV/V

## Environmental Characteristics

### Operating Temperature Range

-65 $^{\circ}$ F to + 250 $^{\circ}$ F.

### Compensated Temperature Range

70 $^{\circ}$ F to 170 $^{\circ}$ F.

*Optional expanded ranges available*

# CNR960

# Series CNR960 Specifications

Baseline Configuration Specs Represented.  
Modifications Encouraged - See Below  
Custom Designs Available

## Dimensions (inches)

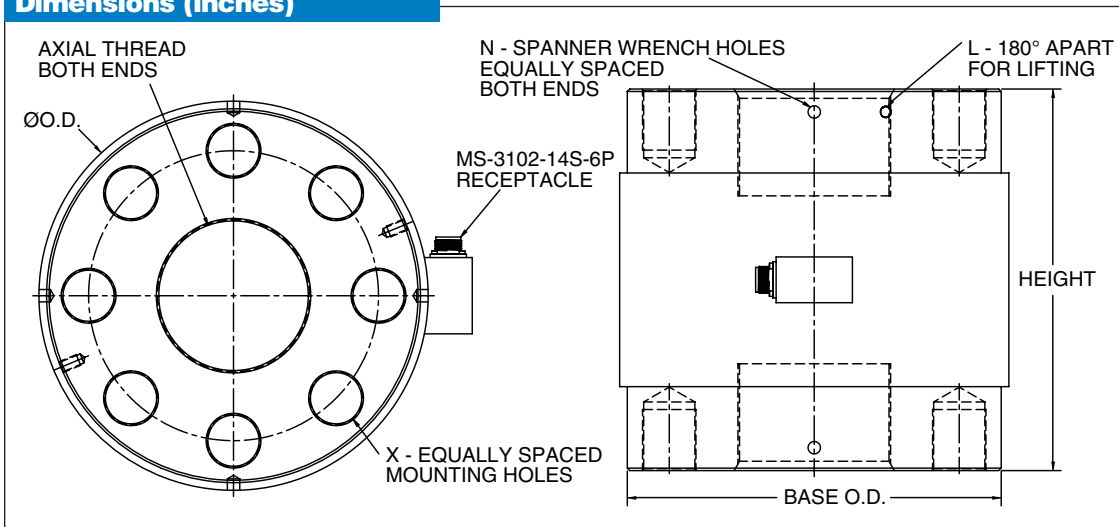

Capacity (lbs.)	Type	ØOD	Base OD	Axial Thread	Height	X	Mounting Holes	N (Each End)	Spanner Wrench Holes	L	Lifting Holes
25K, 50K, 100K, 150K	A	6	5.5	2-12 UN-2B, 2.00 deep	7.0	6	3/4-10 UNC-2B, 1.25 deep, Ø3.50 B.C. Dia.	3	Ø0.38, 0.31 deep	0	n/a
150K, 200K, 300K	B	7.5	7.0	3-12 UN-2B, 3.00 deep	10.0	8	1-8 UNC-2B, 1.50 deep, Ø5.00 B.C. Dia.	6	Ø0.41, 0.38 deep	0	n/a
500K, 800K, 1000K	C	12.8	12.3	5-8 UN-2B, 3.50 deep	12.5	8	1 3/4 -12 UN-2B, 2.0 deep, Ø9.50 B.C. Dia.	4	Ø0.41, 0.38 deep.	2	3/8-16, UNC-2B, 0.65 deep
500K, 800K, 1000K	D	12.8	12.3	5-8 UN-2B, 5.30 deep	16.0	8	1 3/4 -12 UN-2B, 2.0 deep, Ø9.50 B.C. Dia.	4	Ø0.41, 0.38 deep.	2	3/8-16, UNC-2B, 0.65 deep
2000K	E	17.6	17	6-8 UN-2B, 8.25 deep	22.5	12	1 3/4 -12 UN-2B, 3.5 deep, Ø12.00 B.C. Dia.	6	Ø0.41, 0.38 deep	2	3/4-10, UNC-2B, 1.5 deep

## Mechanical Characteristics

**Static Overload Without Damage**  
150% of nominal capacity.

### Calibration

Standard calibration is 5 pts (0, 50%, 100%, 50%, 0) in both tension and compression.

**Important Note:** Factory calibration based on customer's use. Specify if load cell will be mounted using mounting bolt holes or axial threaded hole.

### Material

Electroless nickel-plated carbon steel with painted carbon steel cover.

### Fatigue Life

Greater than 100 million fully reversed cycles at FSO.

## Electrical Characteristics

### Bridge Resistance

350 ohms (Types A, B).  
700 ohms (Types C, D, E).

### Excitation

10 Vdc or 10 Vac.

### Maximum Excitation

> 100 megohms at 50 Vdc at 70°F.

### Insulation Resistance

Greater than 5000 megohms at 50 Vdc @ 70°F.

### Electrical Termination

MS-3102-14S-6P stainless steel electrical receptacle or equivalent.  
*Optional electrical terminations, including Integral cable, are available (consult factory).*

## Electrical Characteristics

### Standard Wiring Code

(Connector pin-outs)

A	+EXC	D	- EXC
B	+SIG	E	N/C
C	- SIG	F	N/C



NOTES: When using a load cell the user must consider load ratings and fatigue life for long term use and structural integrity. Critical loading applications, especially overhead loading, must always be designed with safety redundant load paths. MODIFICATIONS: We realize load cell applications vary greatly and as such our designs are flexible. Specifications subject to change without notice.

WARRANTY: Stellar Technology warrants that its product shall be free from defective workmanship and/or material for a twelve month period from the date of shipment, provided that Stellar Technology's obligation hereunder shall be limited to correcting any defective material FOB our factory. No allowance will be made for any expenses incurred for correcting any defective workmanship and/or material without written consent by Stellar Technology. This warranty is in lieu of all other warranties expressed or implied.

Find More Information at:  
[stellartech.com](http://stellartech.com)

Due to the nature of technology, changes are inevitable. For latest technical specifications, see our website.

237 Commerce Drive • Amherst, NY 14228 • USA

Tel: 716.250.1900 • Fax: 716.250.1909

Email: info@stellartech.com

Copyright © Stellar Technology Incorporated • All Rights Reserved  
Datasheet P/N: 237704B

